

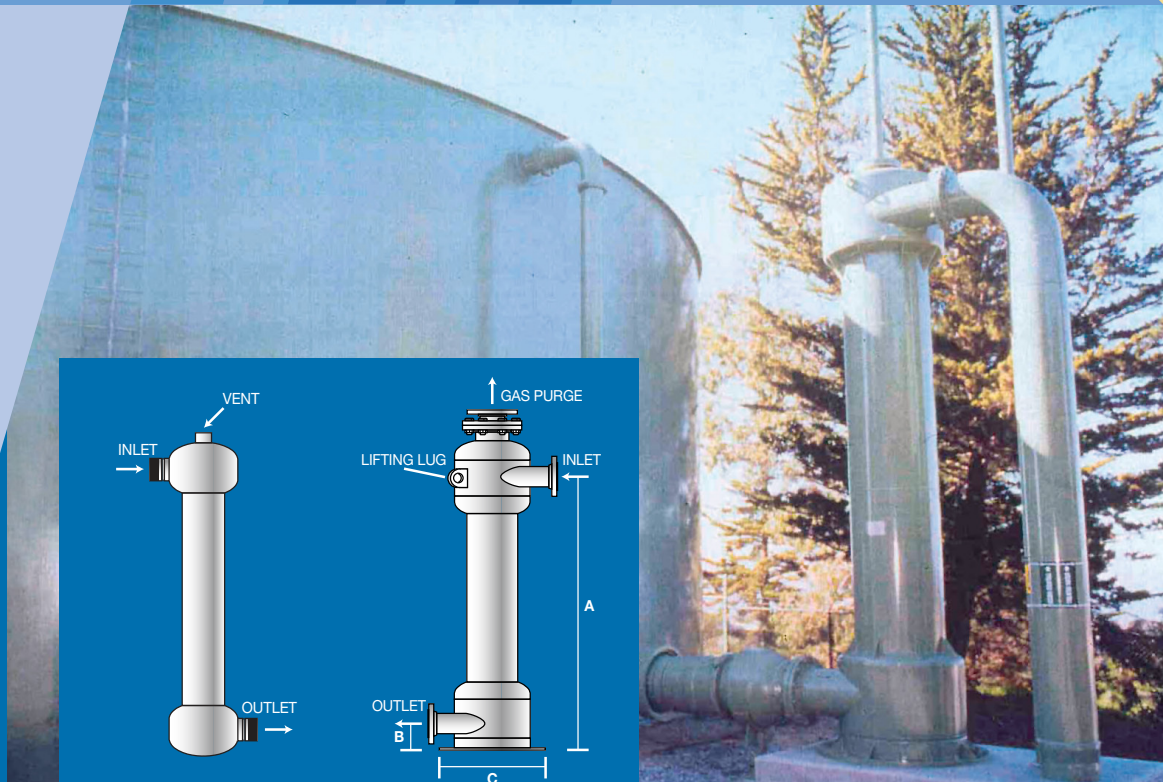

MAZZEI GDT™ DEGAS SEPARATOR

High-Performance
Gas Separation

*World Leader
in Mixing and
Contacting
Technologies*



12" Unit Shown

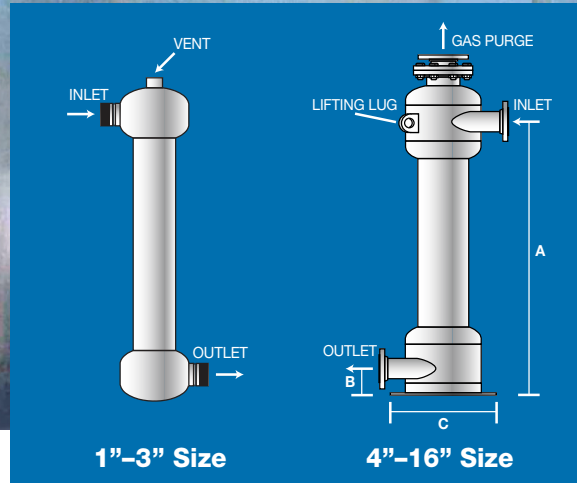

1"-3" Size

4"-16" Size

The Mazzei GDT™ Degaser is a patented unit that utilizes centrifugal force to create a vortex enabling entrained gases to be extracted from water. The water-entrained gas mixture enters the top of the separator tangentially and flows through an accelerator plate, which increases velocity. The water spins down through the separator and exits the bottom. The entrained gas travels through the vortex where it passes into a collector and flows out the top of the separator. The separated gases exit the separator through a degas relief valve.



Powder Coating or Scotchkote™ Interior



Black PVDF Separator



Standard Stainless Steel Separator

Available Options Include:

- ▶ Connections for the 1" – 3" models
- ▶ Various materials of construction (e.g., carbon steel, CPVC, 316L and duplex stainless)
- ▶ Scotchkote™ interior for corrosive applications
- ▶ Powder coated exterior
- ▶ Manufacturing to ASME code

© 2019 Mazzei Injector Company, LLC. MAZZEI®, MIC®, AIRJECTION®, and TRU-BLEND® are registered trademarks of Mazzei Injector Corporation, as is the trade dress of the Mazzei injector under United States Registration No. 3170225. Mazzei products, and processes utilizing those products, are protected under various U.S. and non-U.S. patents and patents pending, including U.S. Patent Nos. 9,744,602; 9,744,502; 9,643,135; 9,643,134; 7,779,664; 7,040,839; 6,890,126; 6,866,703; 6,730,214; 6,193,893.

Contact us today.

Mazzei Injector Company, LLC

500 Rooster Drive

Bakersfield, California 93307-9555

TEL 661-363-6500

FAX 661-363-7500

www.mazzei.net

US	Separator Model Number	Liquid Flow Range (GPM)		Gas Removal Rate (CFM)	Dry Weight (Lbs)	Dimensions (in)			In/Out Connections	Gas Purge Connection
		Minimum	Maximum			A	B	C		
	DS150-PVDF	3	15	3	5	16.5	2.8	6	1" MNPT	1.5" MNPT
	DS100-A	5	35	7	30	21.6	2.6	10.5	1"	1"
	DS150-A	35	75	15	35	24.4	3.3	11	1.5"	1"
	DS200-A	75	130	26	40	30.3	3.3	13.3	2"	1"
	DS300-A	130	300	60	67	44.8	4.3	16.5	3"	1.5"
	DS400-A	250	400	80	279	61.6	6	22	4" Flange	3" Flange
	DS600-A	400	800	160	455	79.3	9	24	6" Flange	3" Flange
	DS800-A	800	1,600	321	1,000	105.5	12.5	36	8" Flange	3" Flange
	DS1000-A	1,200	2,000	401	1,299	146.4	12.5	36	10" Flange	3" Flange
	DS1200-A	2,000	3,500	702	2,649	180.8	18.8	52	12" Flange	4" Flange
	DS1400-A	2,400	4,500	902	4,411	199.3	25.6	50	14" Flange	5" Flange
	DS1600-A	3,200	6,400	1,283	5,285	213	23	70	16" Flange	5" Flange

Metric	Separator Model Number	Liquid Flow Range (LPM)		Gas Removal Rate (LPM)	Dry Weight (Kg)	Dimensions (mm)			In/Out Connections	Gas Purge Connection
		Minimum	Maximum			A	B	C		
	DS150-PVDF	9	57	85	2	419	71	152	25mm MNPT	40mm MNPT
	DS100-A	19	132	199	14	549	66	267	25mm	25mm
	DS150-A	132	284	426	16	620	84	279	40mm	25mm
	DS200-A	284	492	738	18	770	84	338	50mm	25mm
	DS300-A	492	1,136	1,704	30	1,138	109	419	80mm	40mm
	DS400-A	946	1,514	2,271	127	1,565	152	559	100mm Flange	80mm Flange
	DS600-A	1,514	3,028	4,543	206	2,014	229	610	150mm Flange	80mm Flange
	DS800-A	3,028	6,056	9,086	454	2,680	318	914	200mm Flange	80mm Flange
	DS1000-A	4,542	7,570	11,357	589	3,719	318	914	250mm Flange	80mm Flange
	DS1200-A	7,570	13,248	19,875	1201	4,592	478	1,321	300mm Flange	100mm Flange
	DS1400-A	9,084	17,033	25,553	2000	5,062	650	1,270	350mm Flange	125mm Flange
	DS1600-A	12,112	24,224	36,343	2397	5,410	584	1,778	400mm Flange	125mm Flange

Petroleum	Separator Model Number	Liquid Flow Range (BPD)		Gas Removal Rate (MMCFD)	Dry Weight (Lbs)	Dimensions (in)			In/Out Connections	Gas Purge Connection
		Minimum	Maximum			A	B	C		
	DS150-PVDF	86	514	0.004	5	16.5	2.8	6	1" MNPT	1.5" MNPT
	DS100-A	171	1,200	0.010	12	21	2.6	8	1"	1"
	DS150-A	1,200	2,571	0.022	35	24.4	3.3	9	1.5"	1"
	DS200-A	2,571	4,457	0.038	40	30.3	3.3	11	2"	1"
	DS300-A	4,457	10,286	0.087	70	44.8	4.3	16	3"	1.5"
	DS400-A	8,571	13,714	0.116	279	61.6	6	18	4" Flange	3" Flange
	DS600-A	13,714	27,429	0.231	435	79.3	9	24	6" Flange	3" Flange
	DS800-A	27,429	54,857	0.462	1,000	120.5	12.5	32	8" Flange	3" Flange
	DS1000-A	41,143	68,571	0.578	1,299	146.4	12.5	32	10" Flange	3" Flange
	DS1200-A	68,571	120,000	1.011	2,649	180.8	18.8	48	12" Flange	4" Flange
	DS1400-A	82,286	154,286	1.299	3,480	173.8	25.5	54	14" Flange	5" Flange
	DS1600-A	109,714	219,429	1.848	4,795	196.8	23	60	16" Flange	5" Flange

Minimal pressure loss across each unit

Construction is 316L Stainless Steel with glassblast finished exterior or PVDF

Current design maximum pressure is 80 PSI, and maximum temperature is 200° F

Inlet and outlet flanges are 150# RF per ANSI B16.5

The Maximum Gas Flow, listed above, will decrease with lower operating pressures